

HOT INDUCTION BENDS

APCO

营口亚太管件有限公司
APCO PIPE FITTINGS CO.,LTD.
(A BRITISH AND CHINESE JOINT VENTURE)

Factory Site:

No.50, Shiji Road South, Gao Xin Area,
Yingkou 115004, China.

Tel: 86-417-4830203/4893777

Fax: 86-417-4831175

M.p.: 13604329272

E-mail: sales@apcopipe.com

Web: www.apcopipe.com



Hot Induction Bend

APCO's hot induction bends are manufactured in compliance with following applicable standards and non-standard as required by customers.

ASME B 16.49-2007 ASME B 16.25-2007

MSSSP-75-2008 ASME B 31.1-1998, ASME B 31.8-2007

Nominal Pipe Size in.	Outside Diameter O.D.(mm)	BENDING RADIUS (mm)						Angle Bending θ	Tangent length at each end	Wall Thickness (mm)
		3D	4D	5D	6D	8D	10D			
3"	89	267	356	445	534	712	890	90°, 60°, 45°, 30°, 22.5°, or as per the choice of purchaser	350	Sch STD, Sch 10, Sch 20, Sch 30, Sch 40, Sch 80, etc. or as per the choice of purchaser
4"	114	342	456	570	684	912	1140		350	
6"	168	504	672	840	1008	1344	1680		350	
8"	219	657	876	1095	1314	1752	2190		700	
10"	273	819	1092	1365	1638	2184	2730		700	
12"	325	975	1300	1625	1950	2600	3250		700	
14"	356	1068	1424	1780	2136	2848	3560		700	
16"	406	1218	1624	2030	2436	3248	4060		700	
18"	457	1371	1828	2285	2742	3656	4570		1000	
20"	508	1524	2032	2540	3048	4064	5080		1000	
22"	559	1677	2236	2795	3354	4472	5590		1000	
24"	610	1830	2440	3050	3660	4880	6100		1000	
26"	660	1980	2640	3300	3960	5280	6600		1 D (Outside diameter of bend) or as per the choice of purchaser	
28"	711	2133	2844	3555	4266	5688	7110			
30"	762	2286	3048	3810	4572	6096	7620			
32"	813	2439	3252	4065	4878	6504	8130			
34"	864	2592	3456	4320	5184	6912	8640			
36"	914	2742	3656	4570	5484	7312	9140			
38"	965	2895	3860	4825	5790	7720	9650			
40"	1016	3048	4064	5080	6096	8128	10160			
42"	1067	3201	4268	5335	6402	8536	10670			
44"	1118	3354	4472	5590	6708	8944	11180			
46"	1168	3504	4672	5840	7008	9344	11680			
48"	1219	3657	4876	6095	7314	9752	12190			
50"	1270	3810	5080	6350	7620	10160	12700			
52"	1321	3963	5284	6605	7926	10568	13210			
54"	1372	4116	5488	6860	8232	10976	13720			
56"	1422	4266	5688	7110	8532	11376	14220			

Bend end preparation: Welding ends to be beveled as per ASME B 16.25 or as per specified by purchaser

Induction Pipe Bending Standard Bend Tolerances

Bend Angle: $\pm 1/2^\circ$

Bend Radius: $\pm 1\%$

Bend Plane: $\pm 1^\circ$

End squareness

Size NPS 36" and smaller: 2.4 mm (0.09")

Size Greater than NPS 36": 3.0 mm (0.12")

Linear Dimensions

Size NPS 24" and smaller: ± 5 mm (0.19")

Size Greater than NPS 24": ± 6 mm (0.25")

Wall Thickness: $< 0.10\%$ of the bend nominal wall thickness

Ovality within bend: $\leq 3\%$ of the nominal mating pipe outside diameter.

Ovality at the welding Ends: $\leq 1\%$ of the nominal mating pipe outside diameter.

Outside diameter at each welding end: $\pm 1\%$ of the mating pipe outside diameter

Inside diameter at each welding end: Size NPS 36" and smaller: ± 2.5 mm (0.10")

Size larger than NPS 36": ± 3.0 mm (0.12")

Inside diameter at any location in the bend: $> 97\%$ of the minimum specified matching pipe internal diameter.

Closer tolerance than those given above are available when required.

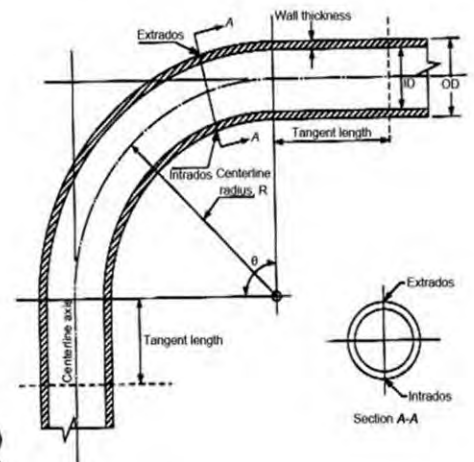

HOT INDUCTION BENDS

APCO

营口亚太管件有限公司
APCO PIPE FITTINGS CO.,LTD.
(A BRITISH AND CHINESE JOINT VENTURE)

Factory Site:

No.50, Shiji Road South, Gao Xin Area,
Yingkou 115004, China.

Tel: 86-417-4830203/4893777

Fax: 86-417-4831175

M.p.: 13604329272

E-mail: sales@apcopipe.com

Web: www.apcopipe.com